



MODULAR 4-WAY TWIN PILOT VALVES

R-433



Twin Pilot 4-Way Valve

Features:

- Indicator shows valve in shaded position
- Micro gap construction - snap action and no blow by
- Dual pilots eliminate shuttle valve
- Balanced design allows speed control at exhausts

Performance:

Flow (SCFM @ 100 psig).....9
 Pilot pressure (psig) minimum.....40
 Temperature.....32° to 180° F
 Working pressure.....0 to 150

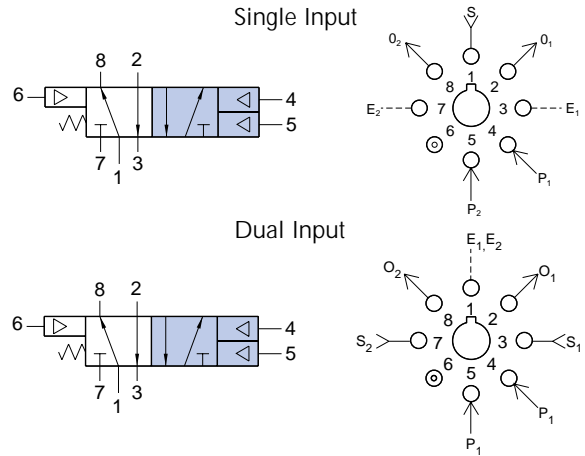

Description:

R-433 is a 5 ported, 4-way valve, with spring return and dual pilots.

R-434



Twin Pilot 4-Way Valve

Features:

- Indicator shows valve in shaded position
- Micro gap construction - snap action and no blow by
- Dual pilots eliminate shuttle valve
- Balanced design allows speed control at exhausts

Performance:

Flow (SCFM @ 100 psig).....9
 Pilot pressure (psig) minimum.....20
 Temperature.....32° to 180° F
 Working pressure.....0 to 150

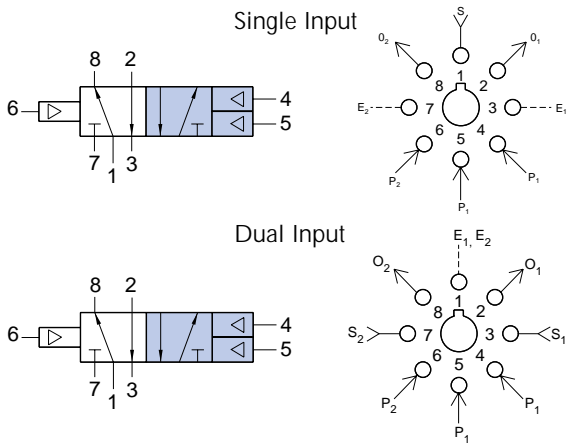

Description:

R-434 is a 5 ported, 4-way, two position, double piloted valve.